

NOVELTIES 2024

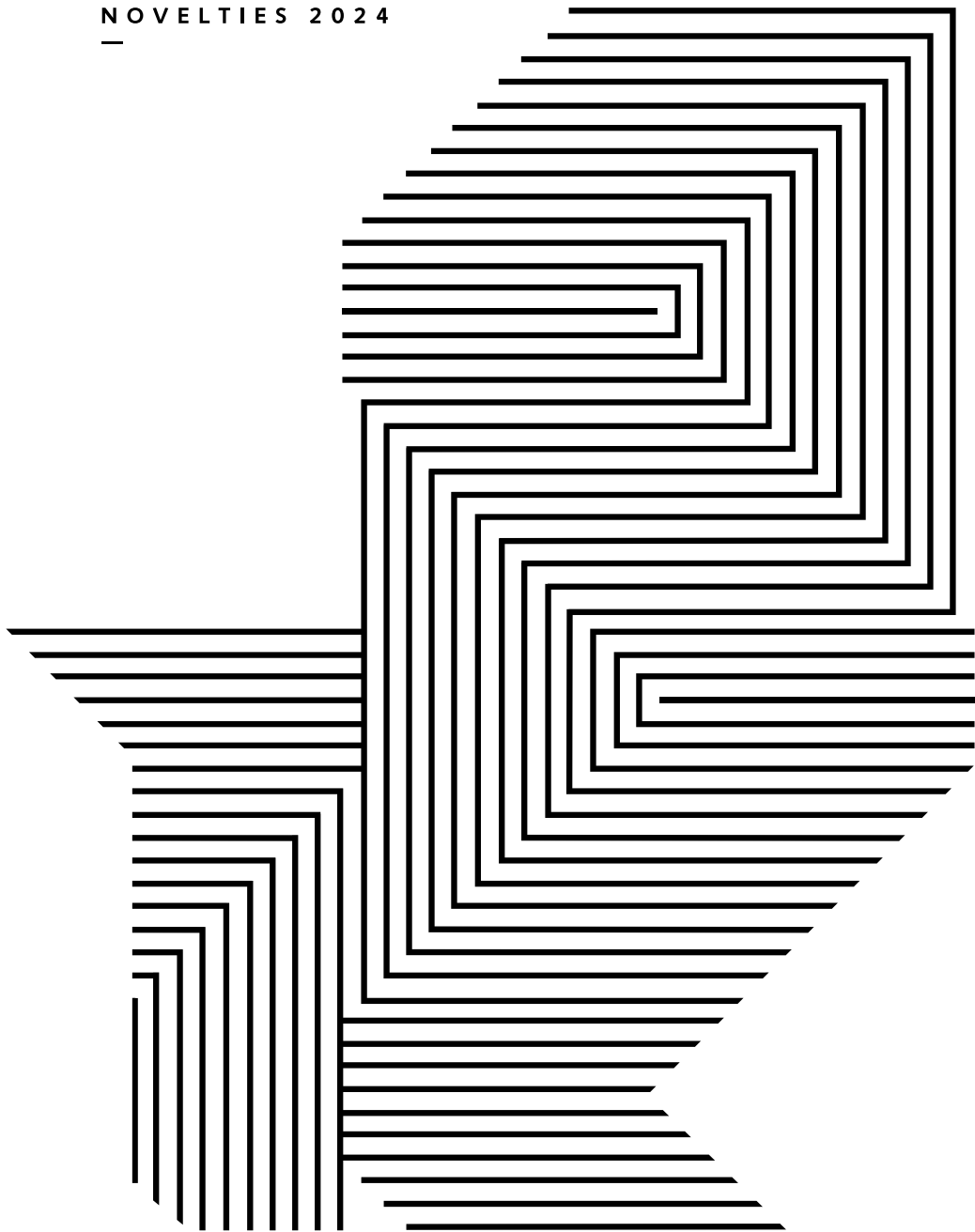

**LIVING**

D I V A N I

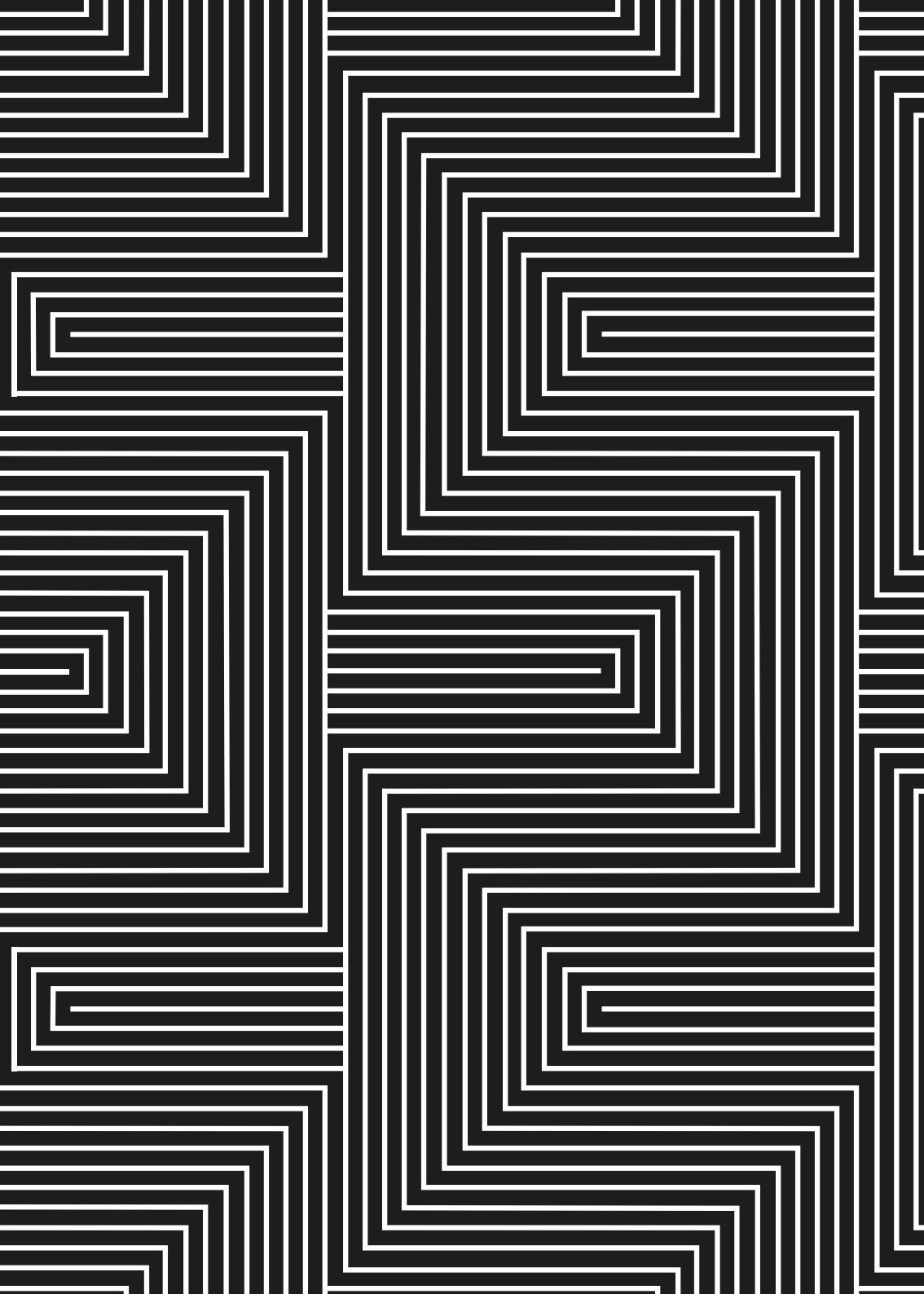

- 09 AD-ASTRA - Marco Lavit
- 29 BALESTRO 24 - Piero Lissoni
- 35 ECHOO - Piero Lissoni
- 45 HALFSQUARE - Giacomo Moor
- 51 ILE CLUB OUTDOOR - Piero Lissoni
- 52 ILE TABLE - Piero Lissoni
- 05 KASUMI - Mist-o
- 15 LORENTZ - David Lopez Quincoces
- 16 LORENTZ LOW TABLE - David Lopez Quincoces
- 23 PEBBLE STOOL - Lanzavecchia + Wai
- 41 SEGNO - Leonardo Talarico



“ Per esaltare la bellezza del legno senza rinunciare alla delicatezza delle forme, abbiamo collegato i due fianchi con una minima struttura in acciaio integrata nelle gambe di legno, che contribuisce ulteriormente a enfatizzare l'aspetto iconico complessivo.

*To enhance the beauty of wood without sacrificing the delicacy of forms, we connected the two sides with a steel structure integrated into the wooden legs, which contributes to further emphasize the overall iconic appearance. ”*

– Mist-o.





**06**

KASUMI / design Mist-o  
ILE TABLE / design Piero Lissoni



“ La tecnica della tornitura dal pieno della materia permette di sviluppare con maestria gli snodi ed i fissaggi tra i vari componenti della lampada, come lo stelo e gli appoggi a terra, mettendone in luce la finezza e la sofisticata artigianalità.

*The technique of turning from solid material allows to skilfully develop the joints and fixings between the various components of the lamp, such as the stem and the ground supports, highlighting the finesse and sophisticated craftsmanship. ”*

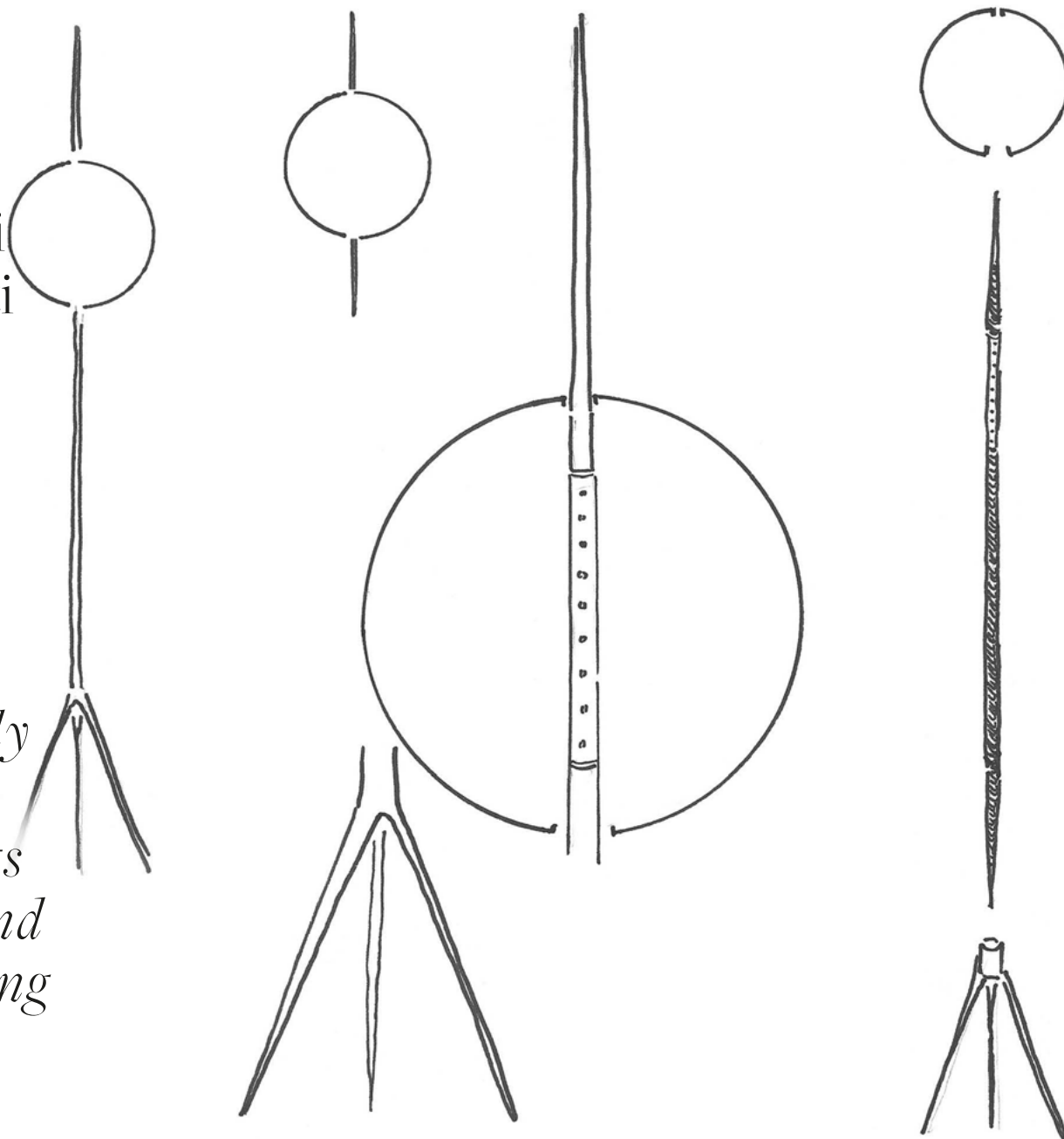

**10**

AD-ASTRA / design Marco Lavit  
BALESTRO 24 / design Piero Lissoni





**12**

AD-ASTRA / design Marco Lavit





“ Lorentz è un divano che si basa sul concetto di componibilità. È leggero, sembra che abbia facoltà di galleggiare nell’aria e può considerarsi un fratello del Kasbah.

*Lorentz is a sofa that is based on the concept of modularity. It is light, it seems to have the faculty to float in the air and can be considered a sibling of Kasbah.* ”

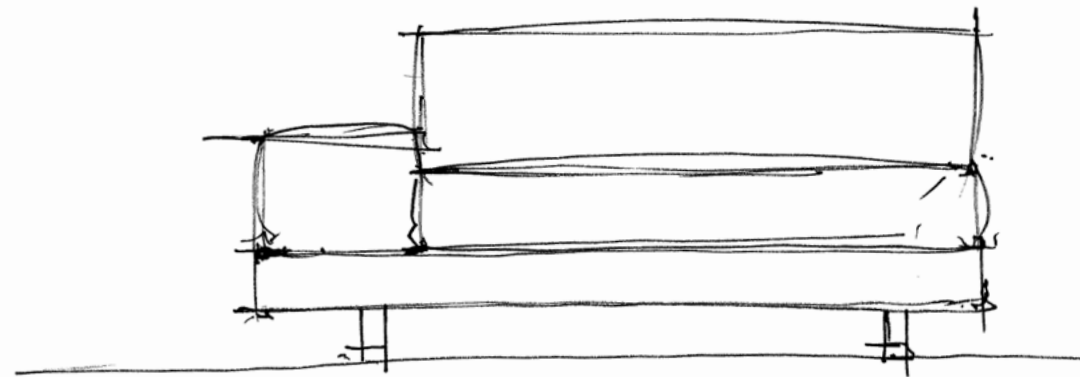
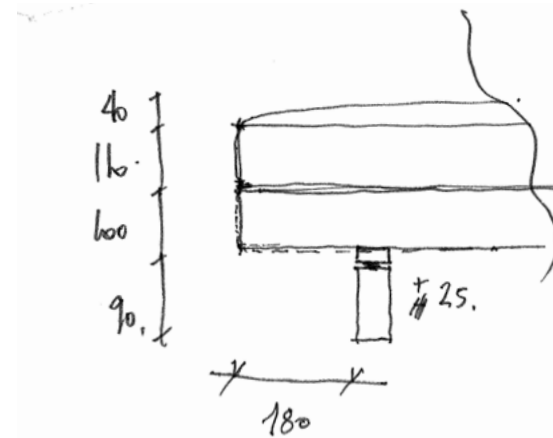





**19**

LORENTZ / design David Lopez Quincoces



“ La differente ampiezza e la forma simmetrica o asimmetrica dello schienale generano tre modelli che, se idealmente alternati, ricordano il ritmo creato dal susseguirsi delle note di uno spartito.

*The different width and the symmetrical or asymmetrical shape of the backrest generate three models that, if ideally alternated, recall the rhythm created by the sequence of notes on a musical score. ”*

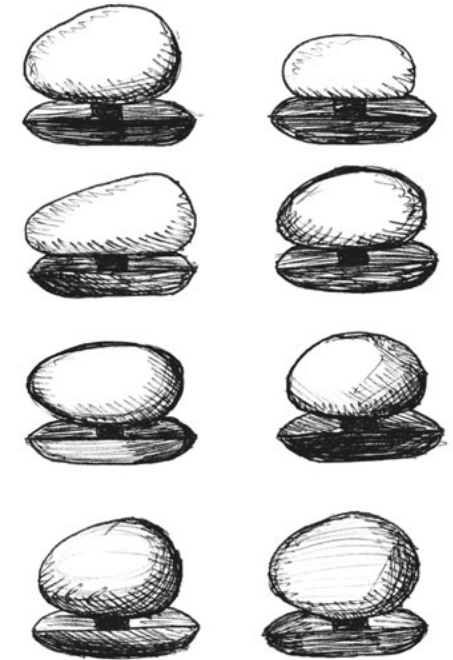
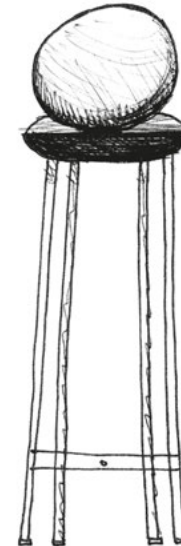
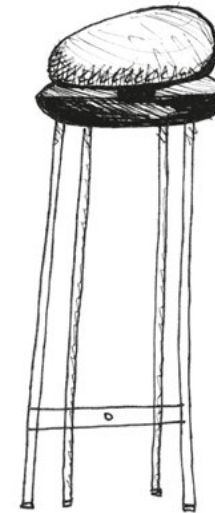
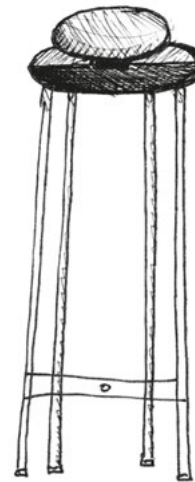

**24**

PEBBLE STOOL / design Lanzavecchia + Wai





“ Balestro è nato un sacco di anni fa, intorno agli anni 90, ma poi si era fermato. Nel 2024 con il cambio delle tecnologie e anche un po' delle dimensioni, arriva Balestro 24, nato intorno all'idea di tornare a parlare di un'eleganza irriverente.

*Balestro was born many years ago, around the 90s, but then it paused. In 2024 with the evolution of both technologies and proportions, comes Balestro 24, developed around the idea of returning to talk about an irreverent elegance. ”*

– Piero Lissoni.

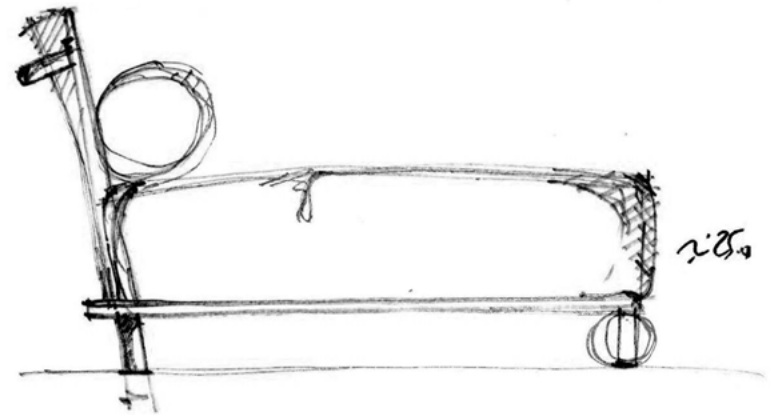
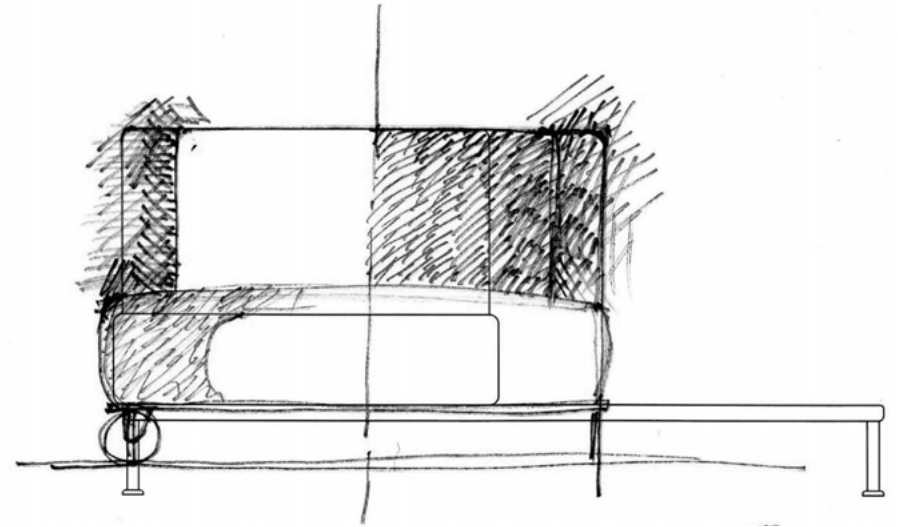





**30**

BALESTRO 24 / design Piero Lissoni



“ Echoo è un divano un pochino classico, ma con un elemento dirompente: è bassissimo e, in alcuni casi, un lato del divano si piega. È come l'eco che rimanda una distorsione. Non è dritto ma si piega ad un certo punto, è questo il suo bello: è nato dritto ma poi è stato distorto.

*Echoo is a sofa somewhat classical, but it has an unconventional element: it is very low and, in some cases, one side of the sofa folds over. It is like the echo that returns a distortion. It's not straight but it bends at a certain point, that's its beauty: it was born straight but then it was distorted.* ”

– Piero Lissoni.

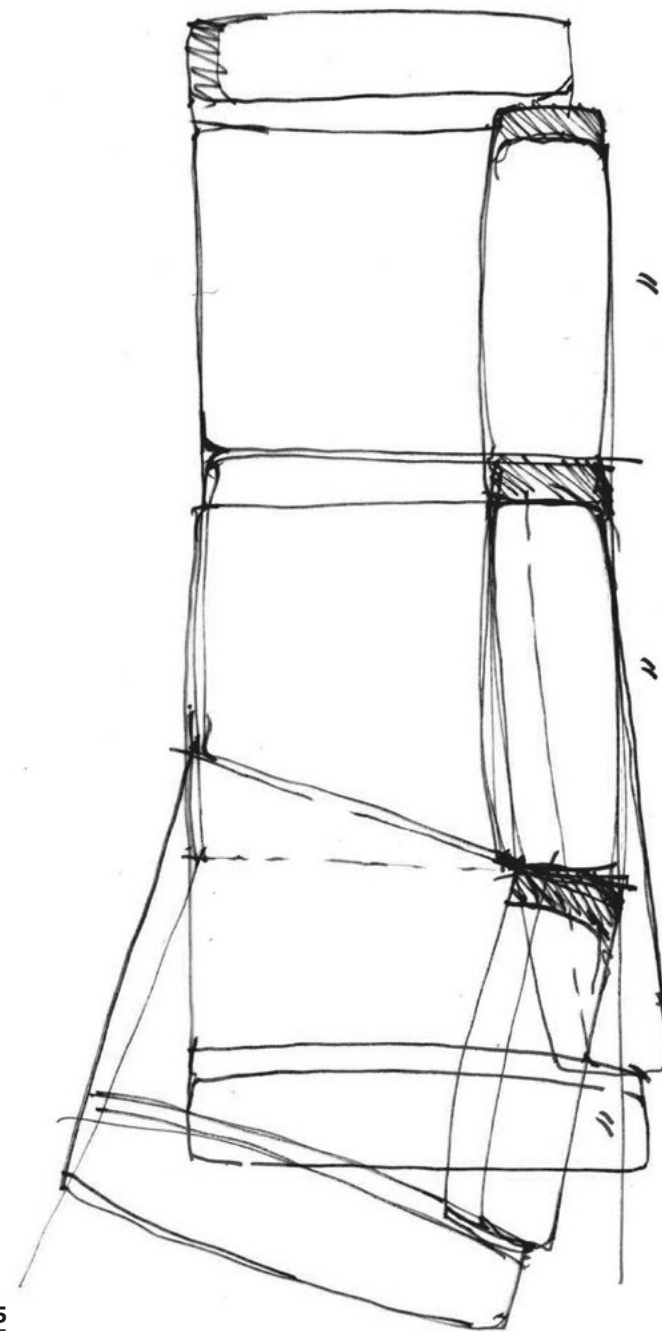

**36**

ECHOO / design Piero Lissoni  
ERA TABLE / design David Lopez Quincoces  
MENHIR / design Piero Lissoni





**38**

ECHOO / design Piero Lissoni

“ Una linea che traccia  
un percorso, un segno grafico  
che disegna un prodotto.

*A line that traces a path,  
a graphic sign that design  
a product.* ”

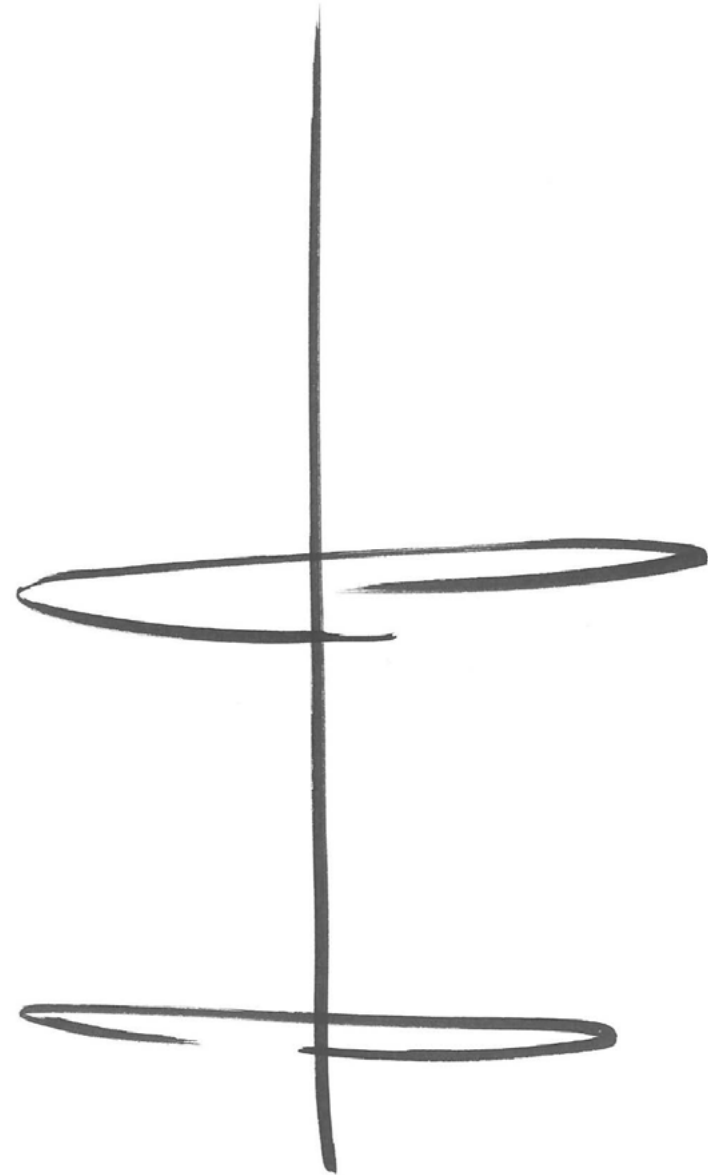



**43**

SEGNO / design Leonardo Talarico

“ La coerenza di segno tra le parti è garantita da una lavorazione inclinata alle estremità dei frontali che ricostruisce, per sottrazione, la geometria triangolare dei montanti e disegna una maniglia per l'apertura dei cassetti.

*The consistency of sign among the parts is guaranteed by sloping manufacturing at the ends of the drawer fronts that reconstructs, by subtraction, the triangular geometry of the uprights and designs a handle for the opening. ”*

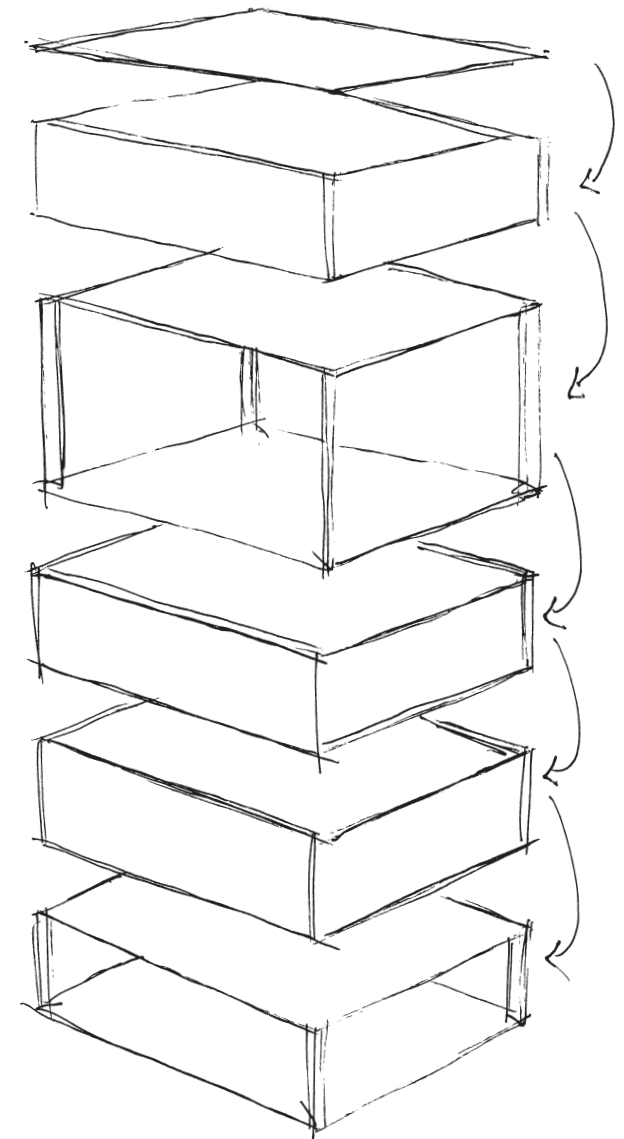
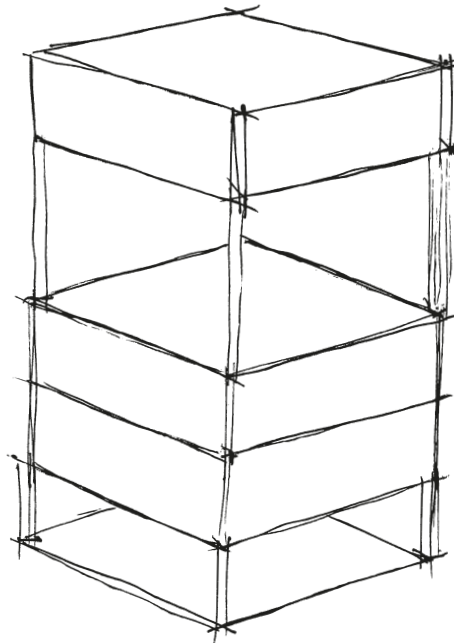





**46**

HALFSQUARE / design Giacomo Moor  
SUMO BED / design Piero Lissoni



“ Ile Club nasce all’inizio del 2000, è come un nido appoggiato sulla mano aperta di un ramo. In questa primavera arriva un altro pezzo della famiglia, e con Ile Club Outdoor spostiamo il nido in giardino.

*Ile Club was born in the early 2000s, and it seems like a nest resting on the open hand of a branch. Another piece of the family arrives this spring, and with Ile Club Outdoor we move the nest to the garden.*”

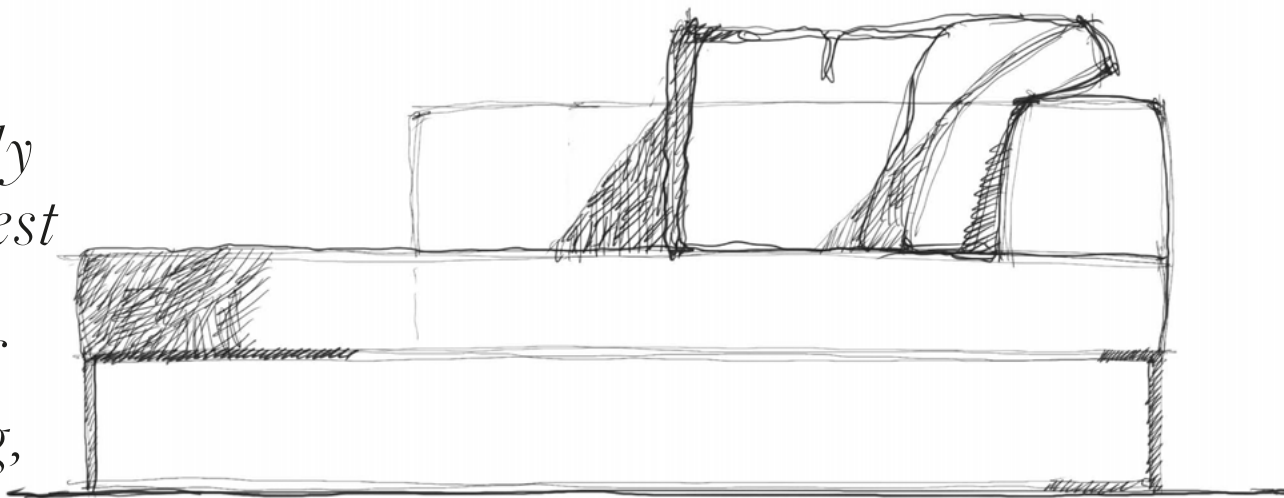





**55**

ILE CLUB OUTDOOR / design Piero Lissoni  
ILE TABLE / design Piero Lissoni

Lissoni Graphx  
render tre.digital  
foto F. Caredda, C. Chimenti, A. Strada  
fotolito Cd Cromo  
print Nava Press  
Made and Printed in Italy

**LIVING DIVANI srl**

Strada del Cavolto, 22040 Anzano del Parco (CO) Italy  
tel. +39 031 630954 - fax +39 031 632590  
info@livingdivani.it www.livingdivani.it

**LIVING DIVANI GALLERY**

Corso Monforte, 20 - 20122 Milano Italy  
tel. +39 0287178662  
gallery@livingdivani.it

@livingdivani #livingdivani  
@livingdivanigallery #livingdivanigallery

member of



Scansiona il Qr Code  
per maggiori informazioni  
sulle News 2024  
Scan the QrCode  
for more info about  
the News 2024



ID Wechat - livingdivani

