

NEXT 2017 | 2018

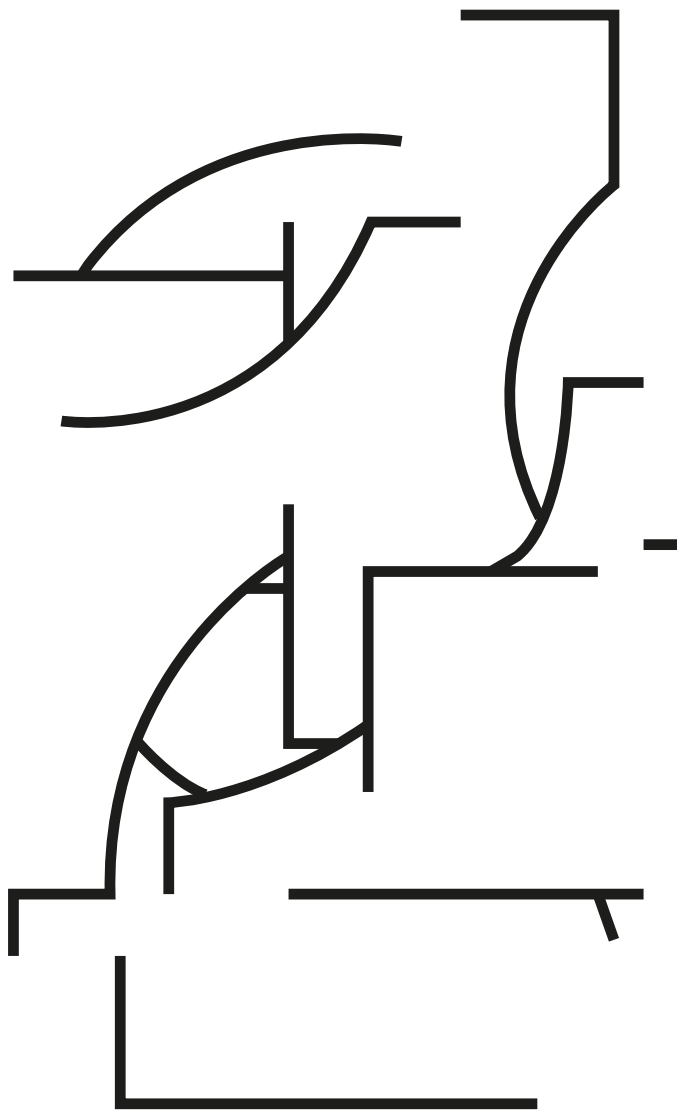

LIVING

D I V A N I

Perfezione e armonia nelle proporzioni e sapore di lusso understated sono il segno di riconoscimento di Living Divani, dinamica e vivace azienda a conduzione familiare che ha fatto dell'imbottito il suo trademark. Nata nei primi anni '70, l'azienda ha tracciato nel tempo un percorso preciso, instaurando un intenso dialogo con la contemporaneità e diventando uno dei punti di riferimento nel panorama del design. Strategica è la collaborazione con Piero Lissoni, che dal 1988 nel duplice ruolo di art director e designer, ne orchestra lo stile unico fatto di discrezione e neutralità formale. Un design calibrato che unisce linee essenziali a funzionalità e comfort, attraverso un lavoro di talent scouting fra le nuove leve del design. Negli anni viene sviluppata un'offerta articolata per arrivare progressivamente ad un ambiente completo, che ruota intorno ad un sistema imbottito dalle forme e volumetrie discrete a cui abbinare dei complementi dal segno più forte – sedie, poltroncine, letti, tavolini, tavoli, librerie e tappeti e la collezione outdoor – che si adattano e definiscono ogni spazio, da quello più essenziale e rigoroso, a quello più eclettico e decorativo. Importante riconoscimento del percorso di eccellenza di Living Divani è l'ingresso nel 2012 in Altagamma, la fondazione che riunisce le imprese italiane di reputazione internazionale che operano nella fascia più alta di mercato.

Perfect, harmonious proportions and a feeling of understated luxury are the distinguishing features of Living Divani, the dynamic and vibrant family-owned Company that has made its trademark of upholstery. Born in the early 1970s, the Company has followed a clear path, maintaining an intensive dialogue with the contemporary world and becoming one of the landmarks in the design landscape. Strategic is the alliance with Piero Lissoni: since 1988, in his dual role as art director and designer, he has led the firm's unique style made of discretion and formal neutrality. A calibrated design that combines clean lines with functionality and comfort, also through an accurate job of talent scouting among young talents, who all share the Company's style and approach to design. Over the years Living Divani has developed a vast and varied offer in a gradual process of creation of a complete living environment, which revolves around the upholstery system, with its subtle shapes and proportions, enhanced by characterful complements - seats, armchairs, beds, tables, bookcases, carpets and the outdoor collection - that will suit and define any setting, from the essential and rigorous to the multifarious and eclectic décor. Significant acknowledgement of the path of excellence of Living Divani is the entry in 2012 in Altagamma, the foundation that gathers Italian companies of international repute, which operate at the top of the market expressing the Italian culture and style both in the business model and the product, renowned for innovation, quality, service, design and prestige.

DIVANI

34	CLIVIO
96	DAYDREAM
66	DUMAS
40	ERA SETTEE
30	ERA SOFA
11	FLOYD
21	FLOYD-HI
58	LIPP DORMEUSE
78	NEOWALL SOFA BED
51	ROD BEAN

POLTRONE E SEDIE

64	CONFIDENT RATTAN
68	DUMAS
56	ERA ARMCHAIR
71	ERA CHAIR
43	ERA EASYCHAIR
74	FLOW
62	LIPP RATTAN
72	MAJA D
98	MINI TOMBOLO
06	RIVULET

TAVOLI E COMPLEMENTI

78	B3
72	BRASILIA
58	CEIBA SCREEN
44	ERA COMODINO
11	ERA TABLE
11	FLOYD TABLE
11	FLOYD-HI TABLE
56	GALILEO
77	GREK BOX
90	JELLY TABLE
21	KIWI
37	NINA
71	NOTES
37	PEBBLE
84	RABBIT & THE TORTOISE COLLECTION
14	TETHYS
47	TONBO
98	WEDGE

OUTDOOR

84	CLIVIO
96	DAYDREAM
92	FLOW
90	JELLY TABLE
98	MINI TOMBOLO
84	RABBIT & THE TORTOISE COLLECTION
90	RIVULET
86	SALE
98	WEDGE

LETTI

44	ROD BED
----	---------

DATI TECNICI / TECHNICAL DATA

103

ARCHETIPICO

ARCHETYPICAL

Lo spazio del pensiero e quello dell'architettura. Forme che costruiscono l'ambiente umano come dimensione ideale, orizzonte estetico senza tempo. Superfici e linee pensate come rappresentazione di una bellezza perfetta: archi, balaustre, colonne, statue, mosaici. L'immaginario prende corpo, si incarna e splende nella materia. Gli oggetti domestici popolano le stanze dell'incanto silenziosamente, segni del presente che giocano con la limpidezza misteriosa della classicità. La interrogano, la dilatano, si fanno suoi testimoni, la prolungano nel qui e ora.

The space of thinking and that of architecture. Silhouettes that define the human environment as an ideal dimension, a timeless aesthetic horizon. Surfaces and lines conceived as the portrayal of a perfect beauty: arches, balustrades, columns, statues, mosaics. The imaginary takes shape, is embodied and shines in substance. The domestic objects silently inhabit the enchanting rooms, contemporary symbols that play with the mysterious clearness of classicism. They question it, they broaden it, they become its witnesses, they keep it in the here and now.



La struttura essenziale di Rivulet in legno è impreziosita da un intreccio decorativo realizzato a mano in cuoio che ne diventa elemento caratterizzante. The essential structure of Rivulet in wood is embellished with a hand-made decorative weave in hide that becomes its characterizing element.





09

RIVULET /



11

FLOYD / ERA TABLE / FLOYD TABLE /
FLOYD-HI TABLE / SIN TITULO /



Tavolino che può accompagnare,
o essere accolto, dall'omonimo
divano Floyd.
Coffee table able to accompany
or be welcomed by the homonymous
Floyd sofa.

13

FLOYD TABLE /



14

FLOYD / FLOYD TABLE /
TETHYS / SIN TITULO /

La forza espressiva del cerchio e l'appeal dei materiali dominano nei tavoli Tethys, richiamando alla memoria un satellite che orbita attorno al proprio pianeta.
The expressive strength of the circle and the magnetism of the materials dominate in the Tethys tables, recalling a satellite that orbits around its own planet.



16

FLOYD / TETHYS /
SIN TITULO /





Floyd intervalla volumi e piattaforme liberamente combinabili a pratici tavolini integrati, per sequenze ogni volta diverse e sorprendenti. Floyd alternates volumes and platforms freely combinable, with practical tables, for compositions that are always different and surprising.

19

FLOYD / ERA TABLE /
FLOYD TABLE / TETHYS /





Il particolare dei cuscini di bracciolo e schienale e il piede scultoreo, classico e hi-tech al tempo stesso, contraddistinguono Floyd-Hi.
The peculiarity of the armrest and backrest cushions and the sculptural foot, classic and hi-tech at the same time, distinguish Floyd-Hi.



24

FLOYD-HI /
ERA TABLE / FLOYD-HI TABLE / KIWI /





Floyd-Hi nella variante ellittica
rappresenta un comfort rassicurante,
da vivere giorno per giorno,
che non rinuncia ai dettagli di stile.
Floyd-Hi in the elliptical version
features a reassuring comfort,
to daily enjoy, that does not ignore
the details of style.



29

FLOYD-HI /

L'esile struttura metallica di Era Sofa sorregge, come per magia, un volume imbottito pieno e soffice, che rivela la maestria nel coniugare pesi e misure. The slender metal structure of Era Sofa holds, as if by magic, a full and soft padded volume, which reveals the mastery in combining weights and measures.

30

ERA SOFA / KIWI /

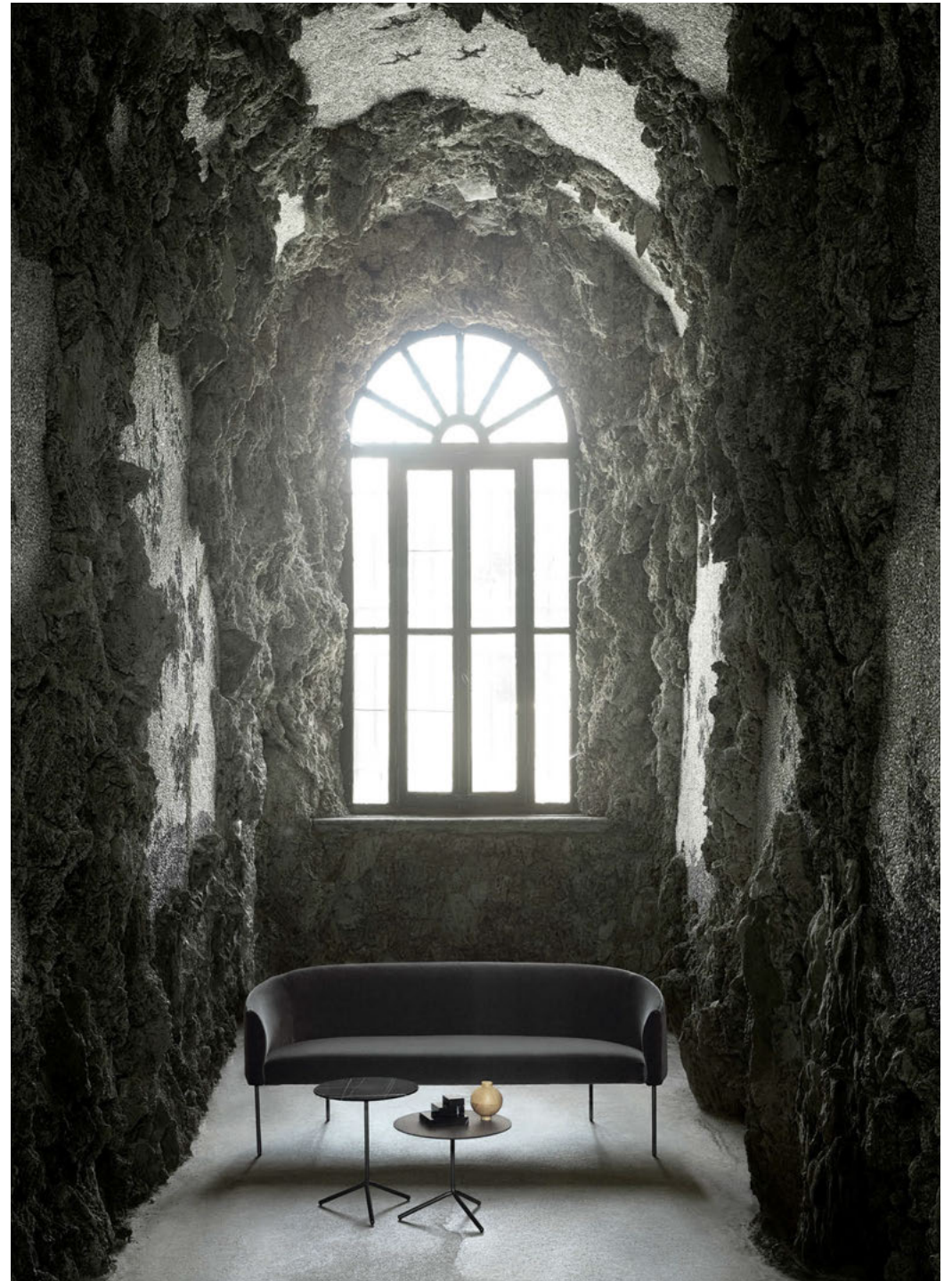



Clivio, oggetto essenziale che diventa un progetto versatile, da lettino a panca, offrendo modalità di fruizione multiple. Clivio, an essential object that becomes a versatile project, from a daybed to a bench, offering multiple ways of use.





37

PEBBLE / NINA /



38

PEBBLE / NINA /



Era Settee è un divanetto a due posti
compatto, ideale per gli spazi di attesa.
Era Settee is a compact two-seater sofa,
ideal for waiting areas.





Ispirazione vintage, gioco di pieni e di vuoti, leggerezza visiva contraddistinguono Era Easychair.
A vintage inspiration, a play of fullness and emptiness and a visual lightness distinguish Era Easychair.

Era Comodino sfoggia gambe metalliche bicolori, top materico in legno e fronte e fianchi brillantemente laccati, che racchiudono il cassetto interno ripartito in sezioni per un ordine impeccabile. Era Bedside table features two-colored metal legs, wood top and brightly lacquered front and sides, which enclose an internal drawer divided into sections for an impeccable order.



44

ERA COMODINO / ROD BED /





Tonbo si caratterizza per la forma cilindrica della base, che si oppone alla struttura in metallo, regalando nell'insieme un risultato armonico fatto di contrapposizioni estetiche. Tonbo is distinguished by a cylindrical base counterpoised to a slender metal structure, making the whole a harmonic play of aesthetic contrasts.

RAZIONALE

RATIONAL

Spazio come racconto del vuoto, della materia da cui si genera. Superfici, tagli, angoli, aperture, sbrecciature, ombre sono la grammatica che lo definisce. Un alfabeto primario, puro, fatto di suoni, silenzi, pause, stacchi. Gli oggetti sono le parole che lo attraversano: poche, esatte, necessarie. Dotate di un senso infallibile della misura e delle proporzioni. Sanno vivere e respirare nell'ampiezza e nella libertà. Nello spazio loro assegnato, trovano senso e risalto.

—

Space as a narrative of the void, of the substance that generates it. Surfaces, cuts, corners, openings, nicks, and shadows are the grammar that defines it. A prime alphabet, pure, comprised of sounds, silences, pauses, and intervals. Objects are the words crossing through the space: few, exact, essential. Endowed with an unerring sense of measure and proportion. They know how to live and breathe in vastness and in freedom. They find meaning and emphasis in the space assigned to them.





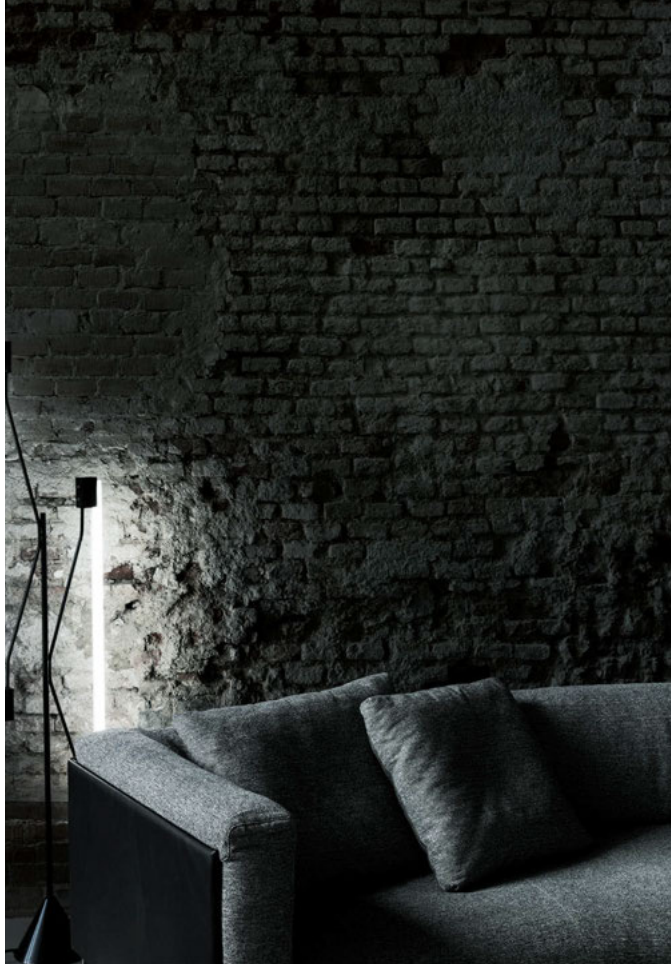

52

ROD BEAN / ERA TABLE /





Dosa geometria e movimento
lo specchio Galileo: oggetto in costante
equilibrio come una sorta di pendolo.
Geometry and movement are combined
in the mirror Galileo; an object
in constant balance like a pendulum.

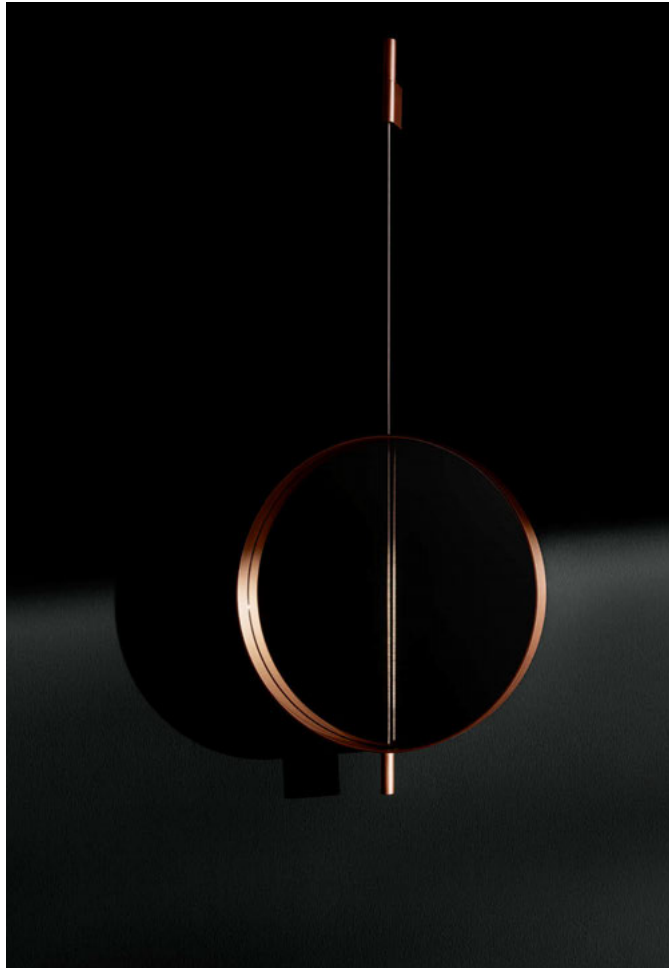

56

ERA ARMCHAIR / GALILEO /





58

LIPP DORMEUSE / CEIBA SCREEN /
ERA TABLE /

Ceiba Screen, un paravento dove candide tele di lino bianco o ricamate ispirandosi all'antica tecnica del pizzo di Cantù, risultano appese ad un sistema di cornici in legno, delineando una stanza inaccessibile allo sguardo dove nascondersi. Ceiba Screen, a séparé in which pure white candid linen canvas or weaved following the ancient crochet technique of Cantù, adorn the wooden frames, in natural or dark-dyed ash wood, outlining an area beyond reach, where to hide.

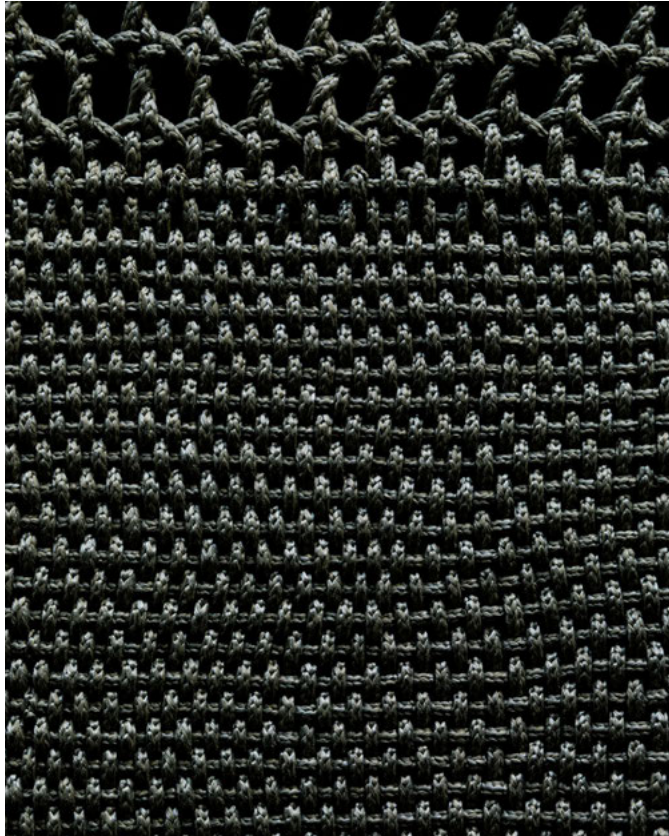

Un raffinato guscio in rattan riveste la poltrona Lipp, che racchiude la persona in un rivestimento trapuntato a rombi. An elegant external rattan covers the Lipp armchair, which encloses the user in diamond-shaped quilting.

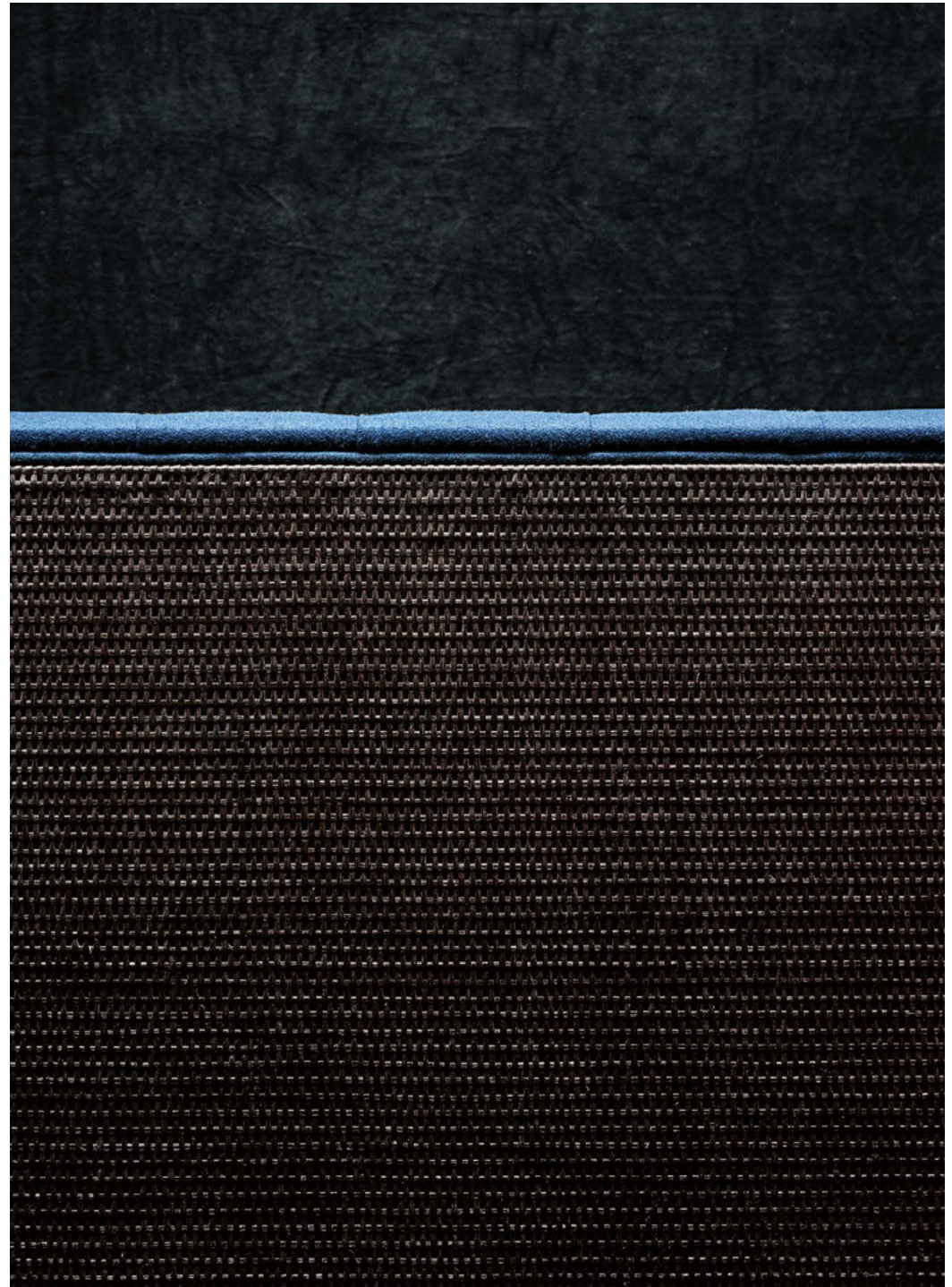

Materiali naturali, sensazioni tattili,
ritorno all'hand-made per la poltroncina
Confident nella versione in rattan dalle
linee arrotondate ed avvolgenti.
Natural materials, tactile sensations,
a return to the hand-made for the roun-
ded and enveloping Confident armchair
with rattan.



64

CONFIDENT RATTAN /





66

DUMAS / ERA TABLE /
SIN TITULO /

La poltrona Dumas si caratterizza per lo schienale basso, da cui emerge un morbido cuscino che si raccorda al bracciolo dolcemente curvato, nel segno dell'assoluta semplicità. The Dumas armchair features a low backrest, with its soft cushion, that is connected, in a gesture of absolute simplicity, to the gently curving armrest.





Sofisticata bellezza per i tavoli Notes, con rigorosa struttura metallica a tre gambe e finitura blu dell'essenziale piano in vetro.

Sophisticated beauty for Notes tables with a rigid metallic structure of three slender legs whose sophisticated appeal is enhanced by the new blue colored finishing of the glass tabletop.



71

ERA CHAIR / NOTES /



Accoglie il corpo accompagnandolo nel relax, in casa così come all'aperto, la sedia a dondolo Flow.
The Flow rocking chair receives the body and accompanies your relaxation at home, as well as at the open air.



74

FLOW / ERA TABLE /





Grek Box è un contenitore a giorno con un geometrico effetto layered, da personalizzare nell'utilizzo sperimentando sempre nuove possibilità di arredo. Grek Box is a storage unit with a geometrical layered effect, whose use can be personalized for ever-new decor possibilities.



78

NEOWALL SOFA BED /
B3 / ERA TABLE / SIN TITULO /





80

NEOWALL SOFA BED /
ERA TABLE / SIN TITULO

OUTDOOR

Un viottolo, una radura, un prato, una piscina, un'altana, un declivio, una siepe, un anfratto. Nel verde ogni cosa rinasce. Due poltroncine sembrano anticipare l'arrivo degli ospiti. Un gruppetto di sedie sogna chi le occuperà. Un tavolino pregusta la sorpresa di un incontro. Un grande divano immagina le conversazioni che saranno intrecciate su di lui. Lo spazio è come un teatro vivente che si apre largo e armonioso, in attesa di essere invaso da voci e presenze.

A path, clearing, meadow, swimming pool, turret, slope, hedge, or cleft. Everything is reborn from green. Two armchairs seem to anticipate the arrival of guests. A group of chairs dream about the people who will sit on them. A coffee table looks forward to the surprise of an encounter. A large sofa imagines the conversations that will be interwoven upon it. The space is like a living theatre which opens up, large and harmonious, waiting to be invaded by voices and presences.





Snello, elegante, disinvolto, Sale
è una presenza sofisticata in un giardino,
a bordo piscina o in una Spa.
Slender, elegant, casual, Sale is a
sophisticated presence in a garden,
by the pool or in a Spa.





88

SALE /









95

FLOW /



96

DAYDREAM /
RABBIT & THE TORTOISE COLLECTION /



98

MINI TOMBOLO / WEDGE /



DATI TECNICI
TECHNICAL DATA

DIVANI

104	CLIVIO
104	DAYDREAM
106	DUMAS
106	ERA SETTEE
108	ERA SOFA
108	FLOYD
111	FLOYD-HI
115	LIPP DORMEUSE
116	NEOWALL SOFA BED
118	ROD BEAN

POLTRONE E SEDIE

104	CONFIDENT
106	ERA ARMCHAIR
106	ERA CHAIR
106	ERA EASYCHAIR
108	FLOW
115	LIPP
115	MAJA D
115	MINI TOMBOLO
118	RIVULET

TAVOLI E COMPLEMENTI

104	B3
104	BRASILIA
104	CEIBA SCREEN
106	ERA COMODINO
108	ERA TABLE
111	FLOYD TABLE
113	FLOYD-HI TABLE
113	GALILEO
113	GREK BOX
113	JELLY TABLE
113	KIWI
116	NINA
116	NOTES
116	PEBBLE
116	RABBIT & THE TORTOISE COLLECTION
121	TETHYS
121	TONBO
121	WEDGE

OUTDOOR

104	CLIVIO
104	DAYDREAM
108	FLOW
113	JELLY TABLE
115	MINI TOMBOLO
116	RABBIT & THE TORTOISE COLLECTION
118	RIVULET
121	SALE
121	WEDGE

LETTI

118	ROD BED
-----	---------

B3

design Victor Vasilev

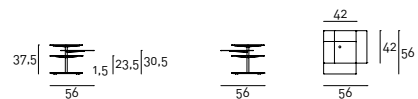

Brasilia

design David Lopez Quincoces

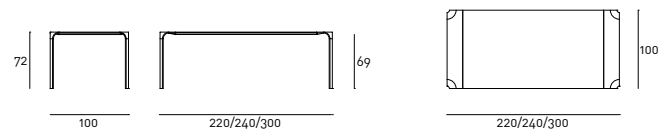

Ceiba Screen

design Luis Arrivillaga

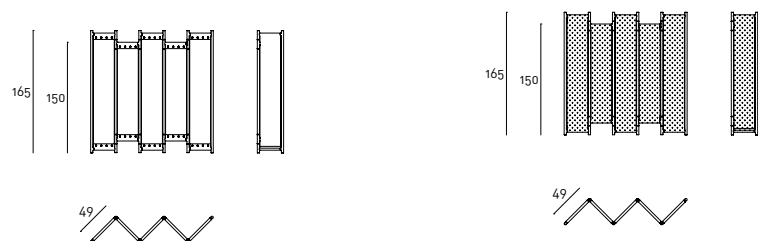

Clivio | Indoor - Outdoor

design Keiji Takeuchi

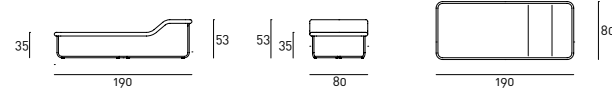

Confident

design Piero Lissoni



Daydream | Indoor - Outdoor

design Mist-o

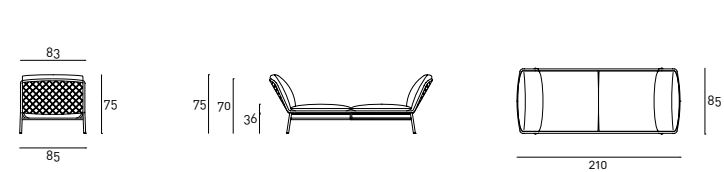

Dumas - Dumas XL

design Piero Lissoni

Poltrona / Armchair

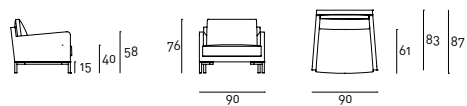

Poltroncina / Easychair

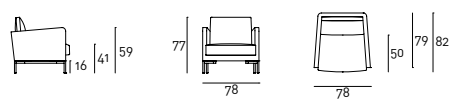

Divani / Sofas

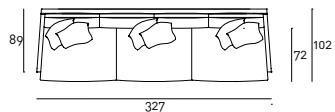
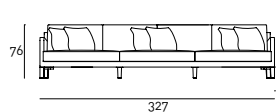
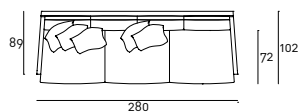
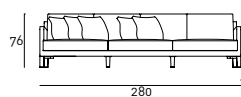
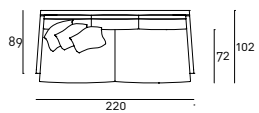
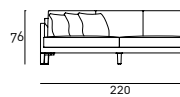
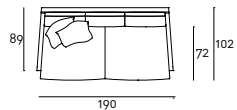
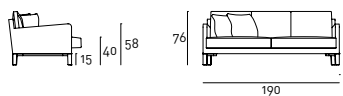

Dumas XL

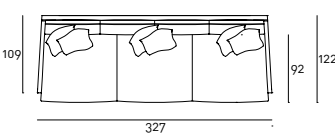
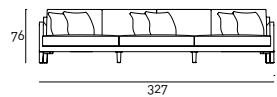
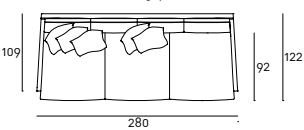
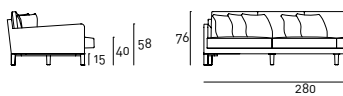

Cuscino / Cushion



Era Armchair

design David Lopez Quincoces

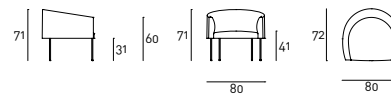

Era Chair

design David Lopez Quincoces

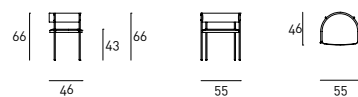

Era Comodino

design David Lopez Quincoces

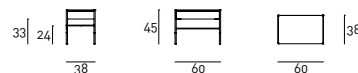

Era Easychair

design David Lopez Quincoces

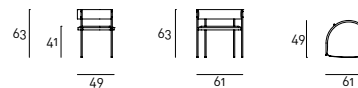

Era Settee

design Design David Lopez Quincoces

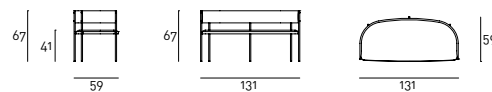

Era Sofa

design David Lopez Quincoces

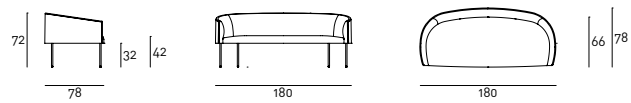

Era Table

design David Lopez Quincoces

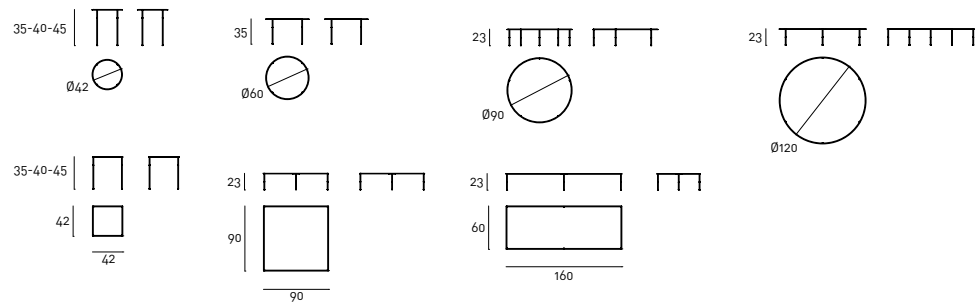

Flow | Indoor - Outdoor

design Shibuleru

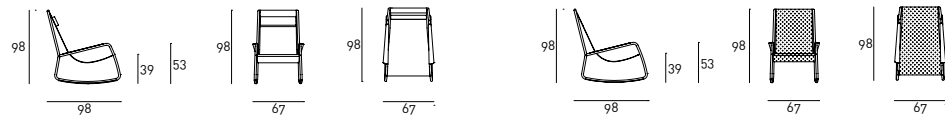

Incordata / Woven

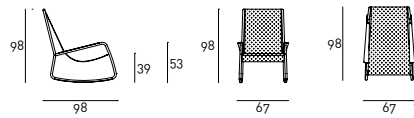

Floyd

design Piero Lissoni

Elemento terminale / Terminal element

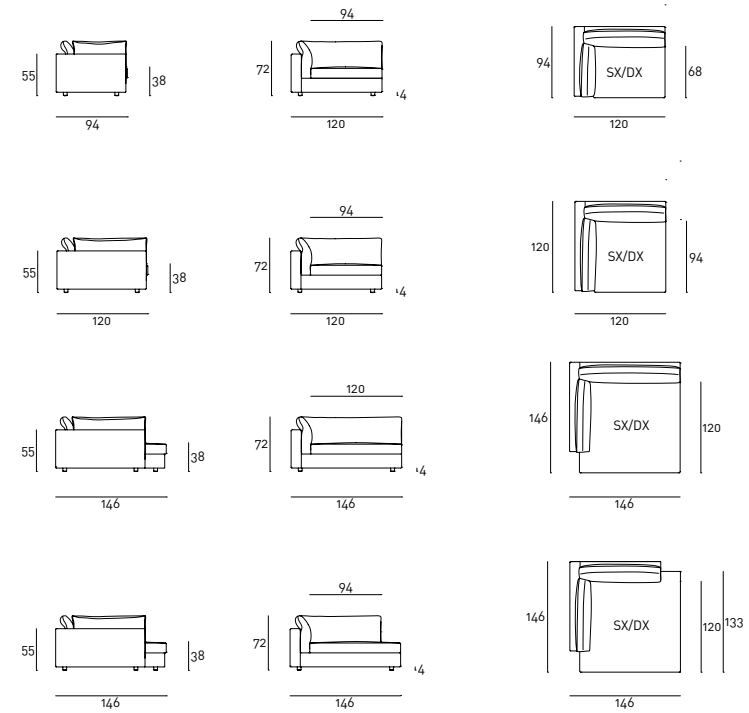

Elemento terminale ovale / Oval terminal element

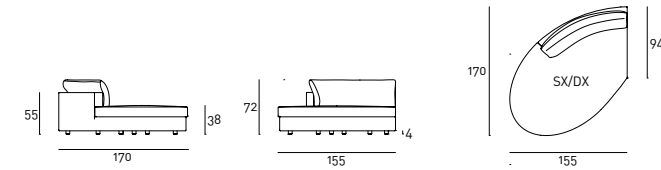

Floyd
design Piero Lissoni

Elemento senza braccioli/ Element without armrests

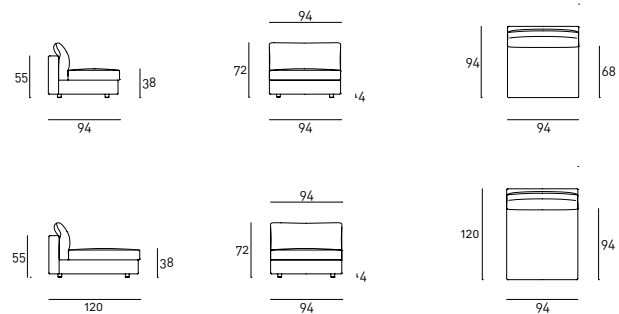

Elemento angolare/ Corner element

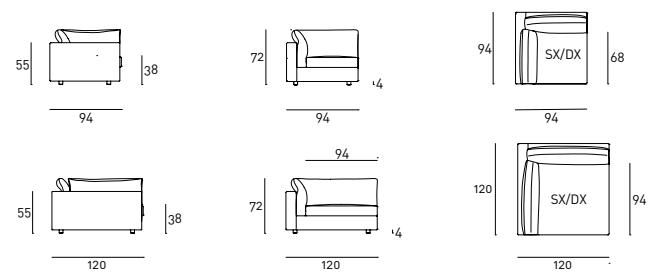

Pouf

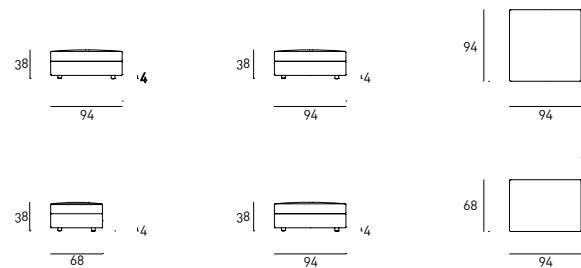

Floyd Table
design Piero Lissoni

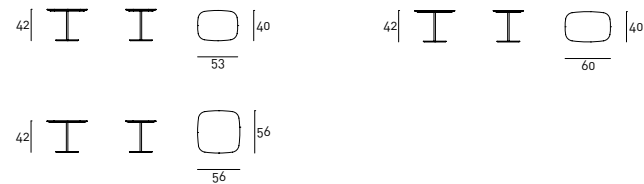

Floyd-Hi
design Piero Lissoni

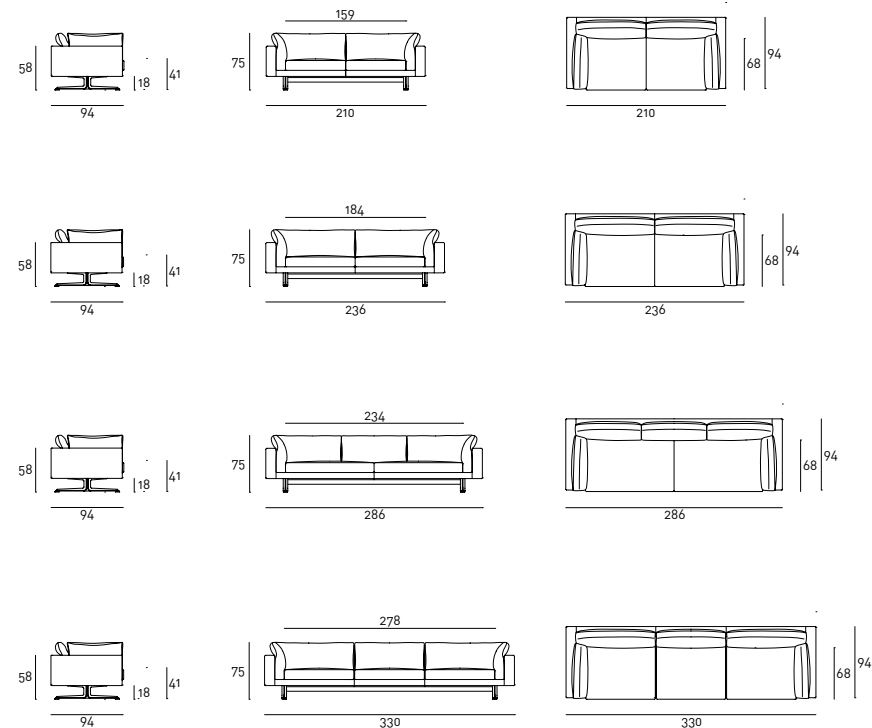

Floyd-Hi
design Piero Lissoni

Elemento ovale/ Oval element

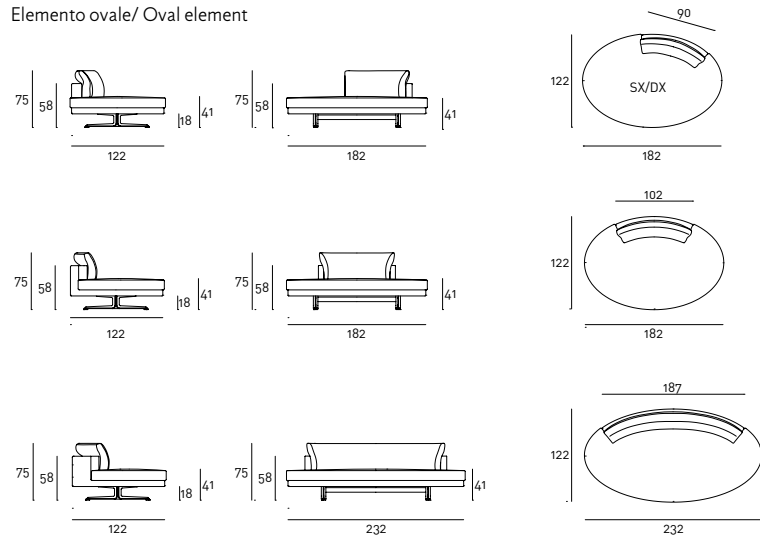

Pouf

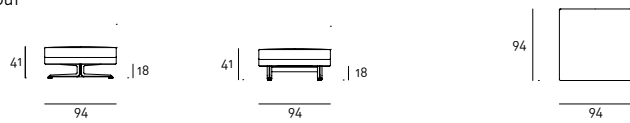

Floyd-Hi Table
design Piero Lissoni

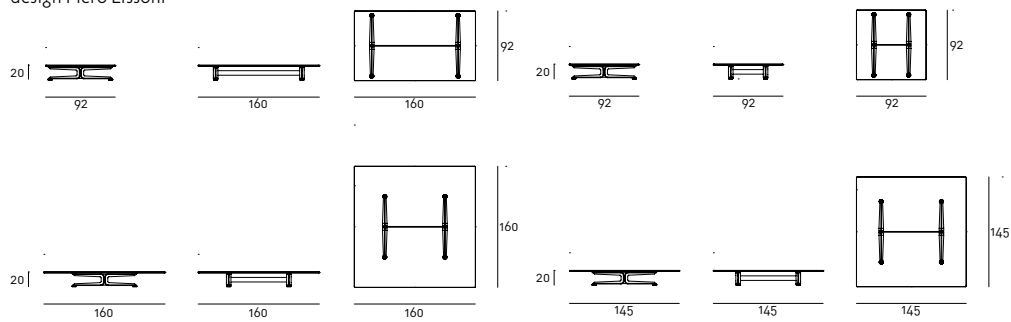

Galileo
design Mario Ferrarini

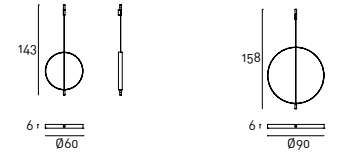

GreK Box
design Gabriele e Oscar Buratti

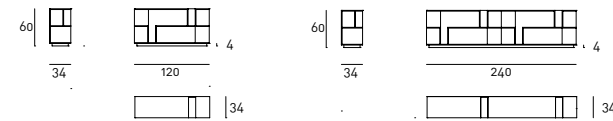

Jelly Table | Indoor - Outdoor
design Piero Lissoni

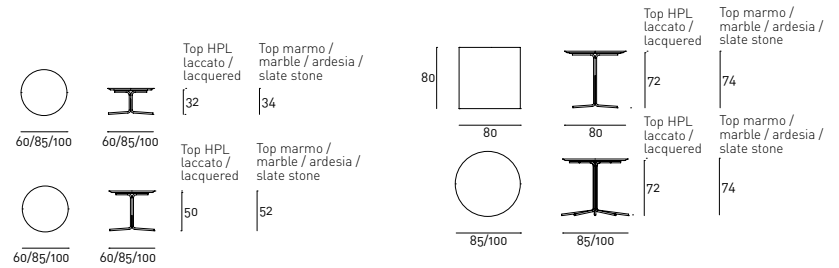

Kiwi
design Keiji Takeuchi



Lipp
design Piero Lissoni

Poltrona / Armchair

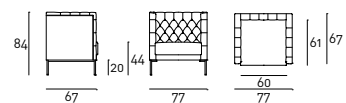
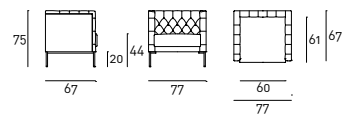

Con Rattan / With Rattan

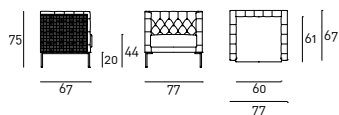

Cuscineti / Cushions

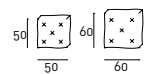

Lipp Dormeuse
design Piero Lissoni

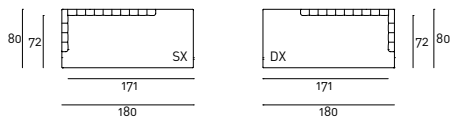
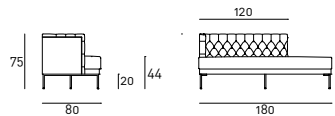

Maja D | Indoor - Outdoor
design Piero Lissoni

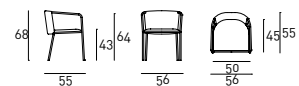

Con Housse / With Housse

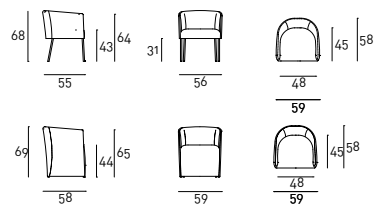

mini Tombolo | Indoor - Outdoor
design Piero Lissoni, - ready made by Studio UN pizzo

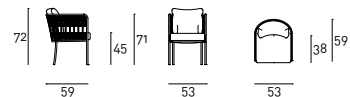

NeoWall Sofa Bed

design Piero Lissoni

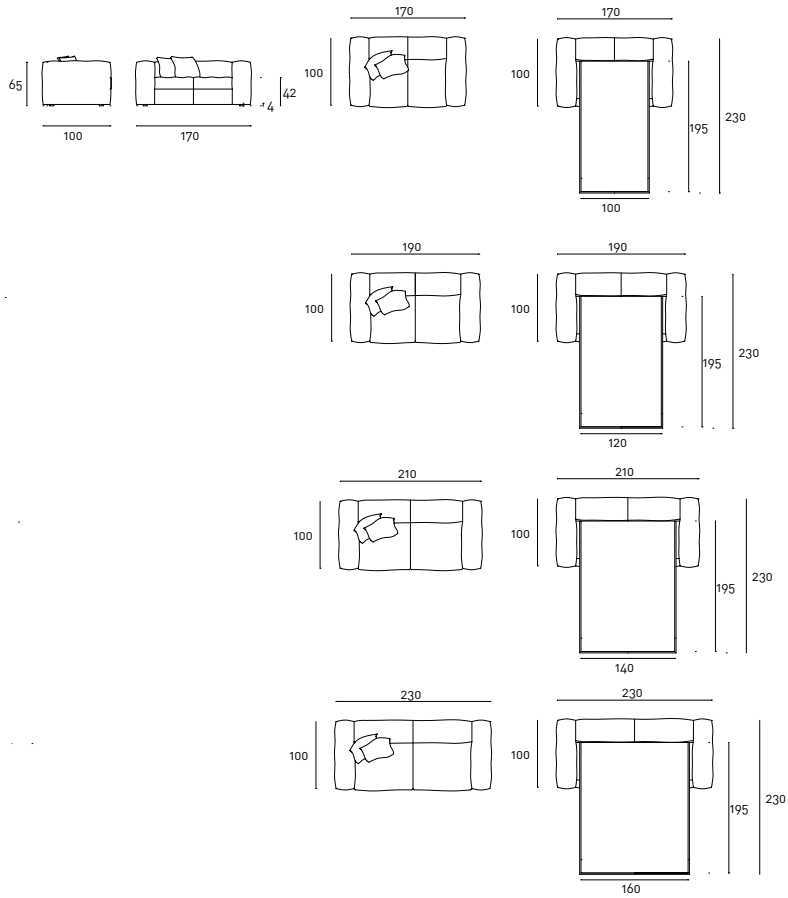

Nina | Indoor - Outdoor

design David Lopez Quincoces

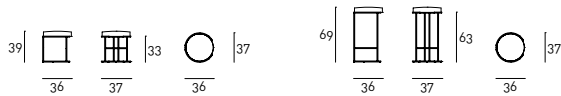

Notes | Indoor - Outdoor

design Massimo Mariani

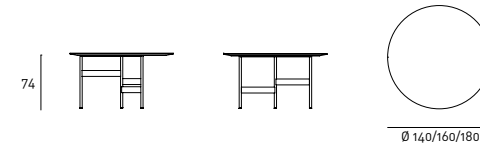

Pebble

design Lanzavecchia + Wai

Scrivania/Writing Desk

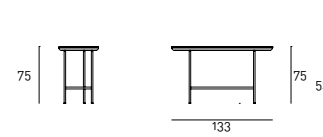

Vanity+ Cassettiera/ Vanity+Drawer

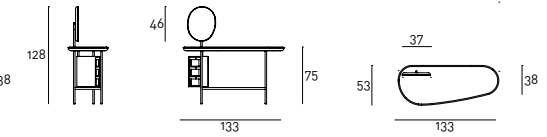

Vanity

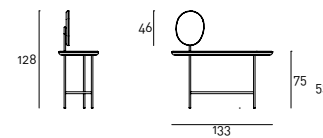

Cassettiera/Drawer

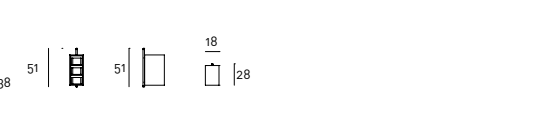

Rabbit & the Tortoise Collection | Indoor - Outdoor

design Studio Juju

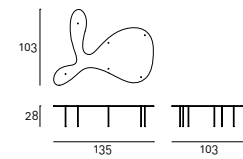

Rabbit Shape

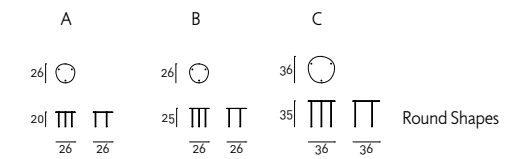

Round Shapes

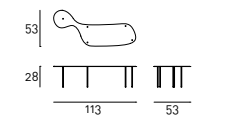

Tortoise Shape

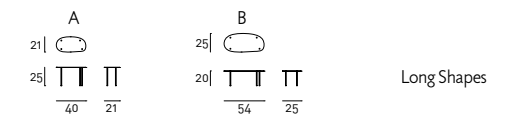

Long Shapes

Rivulet | Indoor - Outdoor

design Junpei & Iori Tamaki

Indoor

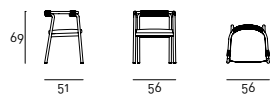

Outdoor

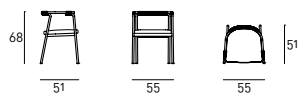

Rod Bean

design Piero Lissoni

Elemento con bracciolo / Element with armrest

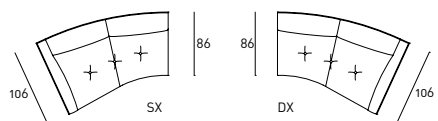
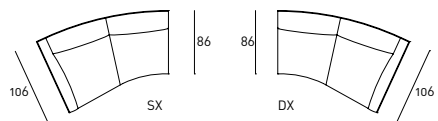
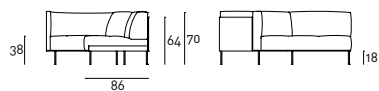

Elemento senza bracciolo / Element without armrest

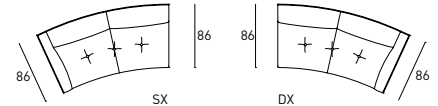
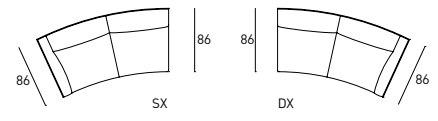
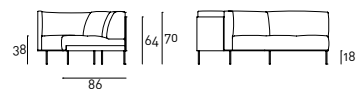
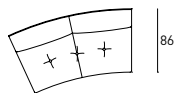
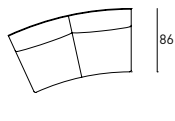
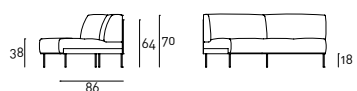

118

RIVULET / ROD BEAN /
ROD BED /

Rod Bed

design Piero Lissoni

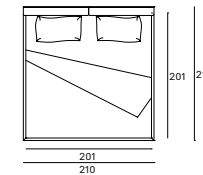
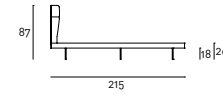
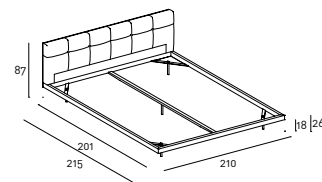
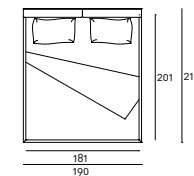
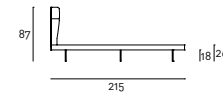
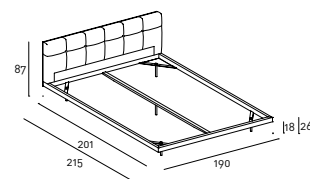
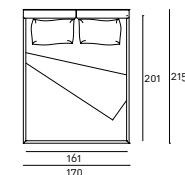
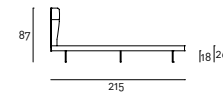
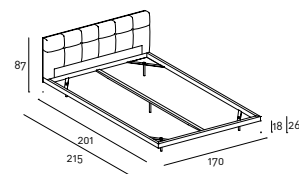
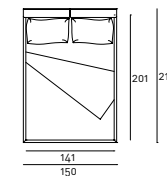
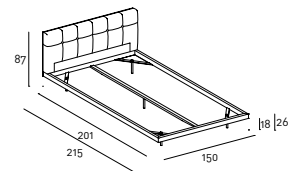
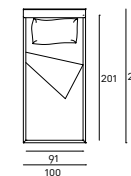
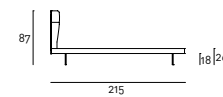
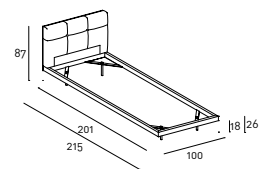

Queen size

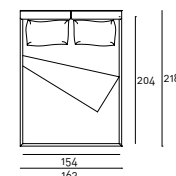
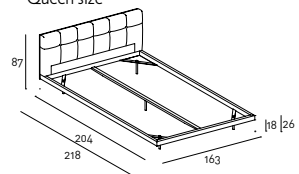

King size

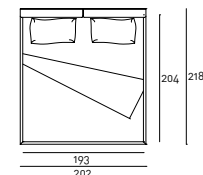
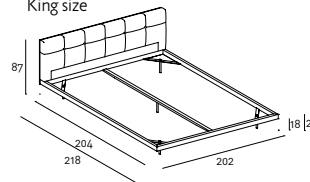

Sale | Indoor – Outdoor
design David Lopez Quincoces

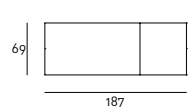
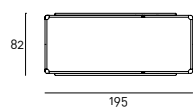
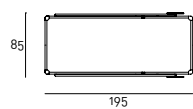
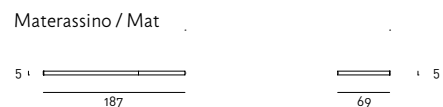
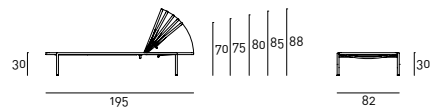
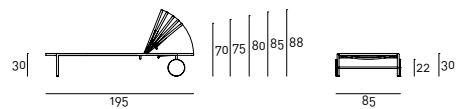

Tethys
design Gabriele e Oscar Buratti

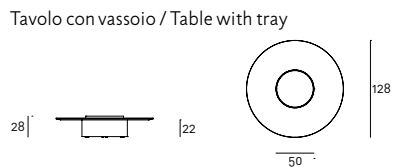
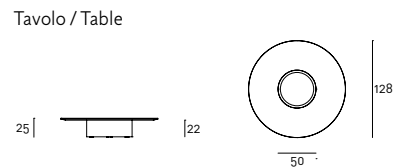

Con top in marmo / With top in marble

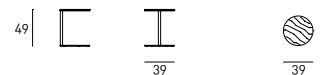
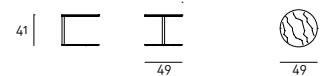

Con vassoio / With tray

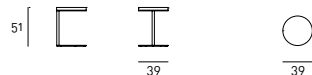
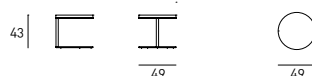

Con top in legno / With top in wood

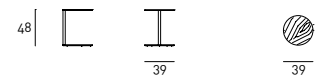
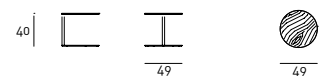

Vassoio / Tray

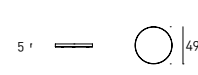
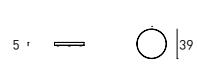

Tonbo
design Junpei & Iori Tamaki

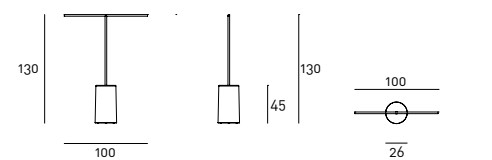
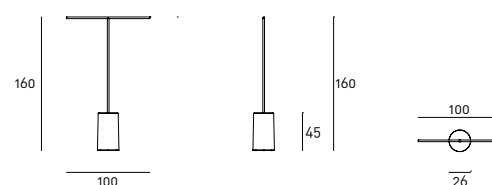

Gruccia / Hanger

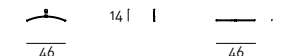

Wedge | Indoor – Outdoor
design Arik Levy

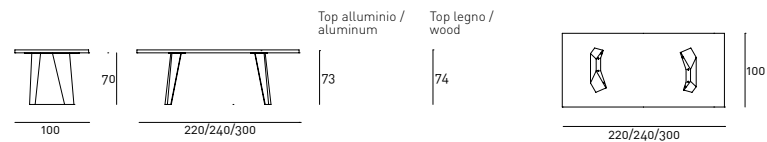

a.d. Graph.X foto T. Sartori styling Elisa Ossino Studio fotolito Cd Cromo stampa Nava Press 2018

Thanks to:

Atelier Areti

Bloc Studios

Davide Giulio Aquini

Edizioni Design

Elena Cutolo

Flos

Fontana Arte

HenryTimi

Kristina Dam

Lambert&Fils

Marsotto Edizioni

Marset

MM Lampadari

Nemo

Oluce

Patricia Ribet

Pietre di Montillo

Restart Milano

Sara Ricciardi

Society Limonta

Studio Testa

Tato

Valentina Cameranesi

Valeria Vasi

Vano Alto

Vitra

When Objects Work

Courtesy of Esh Gallery

Yoichiro KAMEI, Lattice receptacle C3(A), 2011, porcellana - pag. 70

I colori e le finiture, le illustrazioni
e le descrizioni del presente catalogo
sono a titolo indicativo e non vincolante.
Living Divani si riserva il diritto
di apportare, anche senza preavviso,
modifiche di carattere tecnico e produttivo.
The colours, finishes, illustrations
and descriptions in this catalogue
are provided solely by way of example.
Living Divani reserves the right to make
technical and design changes without
prior notice.

member of



Made and Printed in Italy



ID Wechat - livingdivani

LIVING DIVANI srl
Strada del Cavolto, 22040 Anzano del Parco (CO) Italy
tel. +39 031 630954 - fax +39 031 632590
info@livingdivani.it www.livingdivani.it